

# LINOVECTOR II

LV2-T8 11 14  
Copper/Aluminum and  
Steel Element Ratings

## Submittal

# Specification

### LV2 Slip Jointed Enclosure

#### ENCLOSURE:

STYLE: Slope Top, Slope Outlet  
OUTLET: Stamped Louvers  
Pencil Proof

LENGTHS: 2'0" thru 8'0" in 6" Increments  
MAT'L:  16 Ga. CRS (Std)  
 14 Ga. CRS (Opt'l)  
 16 Ga. Stainless Steel (Opt'l)  
 14 Ga. Stainless Steel (Opt'l)  
 14 Ga. Aluminum (Opt'l)  
 12 Ga. Aluminum (Opt'l)

HEIGHT:  8"  
 11"  
 14"

FINISH:  Baked Powder (Std)  
 Baked Metallic (Opt'l)

#### ACCESSORIES:

LV Overlapping Type

All accessories return to the wall at the bottom and have pre-punched holes for fastening to the wall.

### LV2-T8

ELEMENT TUBE SIZE	FIN SIZE HEIGHT x WIDTH	CRADLE NUMBER	A
* 3/4 COPPER	2 1/2 x 2 1/4	1	4 5/16
* 3/4 COPPER	2 1/2 x 2 3/4	1	5"
* 3/4 COPPER	3 3/4 x 2 3/4	2	5"
* 1" COPPER	2 1/2 x 2 3/4	1	4 1/2
1" COPPER	3 3/4 x 2 3/4	2	5 3/16
1" COPPER	5" x 2 3/4	3A	5 1/2
1 1/4 COPPER	3 3/4 x 2 3/4	2	5 5/16
1 1/4 COPPER	5" x 2 3/4	3A	5 11/16
1" STEEL	3 3/4 x 2 3/4	2	5 5/16
1" STEEL	5" x 2 3/4	3A	5 11/16
1 1/4 STEEL	3 3/4 x 2 3/4	2	5 1/2
1 1/4 STEEL	5" x 2 3/4	3A	5 15/16

\* Damper available with these elements only.

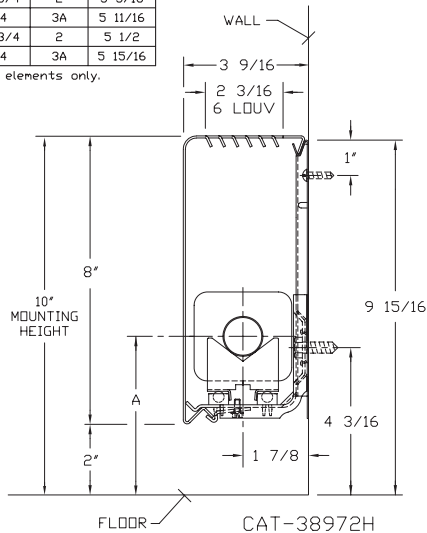

CAT-38972H

### LV2-T11 14

ELEMENT TUBE SIZE	FIN SIZE HEIGHT x WIDTH	CRADLE NUMBER	A
* 3/4 COPPER	2 1/2 x 2 1/4	1	4 5/16
* 3/4 COPPER	2 1/2 x 2 3/4	1	5 1/2
* 3/4 COPPER	3 3/4 x 2 3/4	2	5"
* 1" COPPER	2 1/2 x 2 3/4	1	4 1/2
1" COPPER	3 3/4 x 2 3/4	2	5 3/16
1" COPPER	5" x 2 3/4	3A	5 1/2
1 1/4 COPPER	3 3/4 x 2 3/4	2	5 5/16
1 1/4 COPPER	5" x 2 3/4	3A	5 11/16
1" STEEL	3 3/4 x 2 3/4	2	5 5/16
1" STEEL	5" x 2 3/4	3A	5 11/16
1 1/4 STEEL	3 3/4 x 2 3/4	2	5 1/2
1 1/4 STEEL	5" x 2 3/4	3A	5 15/16

\* 2 tier with damper available in 14" height with these elements only.

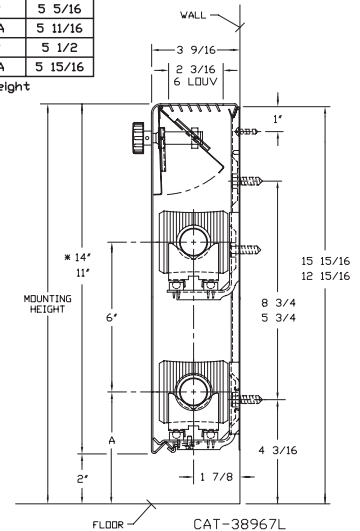

CAT-38967L

#### ELEMENT:

TYPE:  Cu/AL (Mechanically Expanded)  
LENGTHS: 2'0" thru 12'6" in 1" Increments for 1" & 1-1/4" Cu.  
2'0" thru 8'0" in 1" Increments for 3/4" Cu.

One End Flared (Std)

TYPE:  IPS Steel (Mechanically Expanded)

LENGTHS: 2'0" thru 12'6" in 1" Increments  
 NPT Thread both Ends (Std)  
 Beveled Ends for Field Weld (Opt'l)

See Catalog for Working Pressures

#### BACKPLATE:

TYPE:  Partial B/P  
LENGTHS: 8'0" Only  
MAT'L:  20 Ga. Prepainted (Std)  
 18 Ga. Galvannealed (Opt'l)

TYPE:  Full Ht. B/P (Opt'l)  
LENGTHS: 2'0" thru 8'0" in 6" Increments  
MAT'L:  20 Ga. Galvannealed (Opt'l)  
 20 Ga. Painted (Opt'l)  
 18 Ga. Painted (Opt'l)

#### AIRSEAL:

1/8" x 3/8" Closed Cell (Opt'l)

#### BRACKETS:

Water Brkt w/B.B.  
 Wall Mtd Hngr for 2nd Tier

#### DAMPER:

Damper Blades Factory Installed  
 Knob Damper (Opt'l)  
 Tamper Resistant (Opt'l)

Not recommended for steam applications, consult factory.

# Vulcan

RADIATOR

260 North Elm St., Westfield, MA 01085  
(413) 568-9571 Fax: (413) 564-5661  
www.vulcanrad.com

PROJECT: \_\_\_\_\_ DATE: \_\_\_\_\_  
LOCATION: \_\_\_\_\_  
ARCHITECT: \_\_\_\_\_  
ENGINEER: \_\_\_\_\_  
CONTRACTOR: \_\_\_\_\_  
PO NUMBER: \_\_\_\_\_

# STYLE "LV2-T8 11 14" LINOVECTOR II

## COPPER/ALUMINUM ELEMENTS

ALL RATINGS ARE IN BTU/HR/LIN FT AND BASED ON 3 FPS VELOCITY, 65° EAT

TUBE SIZE	CATALOG DESIGNATION	FIN SIZE HEIGHT X WIDTH	FINS PER FT.	FIN THICKNESS IN INCHES	ENCL HEIGHT IN INCHES	TIERS AND CENTERS IN INCHES	MOUNTING HEIGHT IN INCHES	STEAM 215° FACTOR	HOT WATER (AVG.)										
									200°	190°	180°	170°	160°	150°	140°	130°	120°	CORRECTION FACTORS FOR AVERAGE WATER TEMPERATURES	
									1.00	0.86	0.78	0.69	0.61	0.53	0.45	.40	.33	.26	
3/4"	VR01	2-1/2" x 2-1/4"	50	.011	8*	1	10	750	650	590	520	460	400	340	300	250	200		
					11	1	13	810	700	630	560	490	430	360	320	270	210		
					14	1	16	870	750	680	600	530	460	390	350	290	230		
					14*	2-5 CL	16	1240	1070	970	860	760	660	560	500	410	320		
3/4"	VR02	2-1/2" x 2-3/4"	60	.010	8*	1	10	900	770	700	620	550	480	410	360	300	230		
					11	1	13	960	830	750	660	590	510	430	380	320	250		
					14	1	16	1120	960	870	770	680	590	500	450	370	290		
					14*	2-5 CL	16	1570	1350	1220	1080	960	830	710	630	520	410		
1"	VR03	2-1/2" x 2-3/4"	55	.011	8*	1	10	880	760	690	610	540	470	400	350	290	230		
					11	1	13	940	810	730	650	570	500	420	380	310	240		
					14	1	16	1000	860	780	690	610	530	450	400	330	260		
					14*	2-5 CL	16	1440	1240	1120	990	880	760	650	580	480	370		
3/4"	VR04	3-3/4" x 2-3/4"	50	.014	8*	1	10	1080	930	840	750	660	570	490	430	360	280		
					11	1	13	1140	980	890	790	700	600	510	460	380	300		
					14	1	16	1200	1030	940	830	730	640	540	480	400	310		
					14*	2-5 CL	16	1590	1370	1240	1100	970	840	720	640	520	410		
1"	VR05	3-3/4" x 2-3/4"	50	.011	8*	1	10	1070	920	830	740	650	570	480	430	350	280		
					11	1	13	1130	970	880	780	690	600	510	450	370	290		
					14	1	16	1190	1020	930	820	730	630	540	480	390	310		
					14*	2-5 CL	16	1580	1360	1230	1090	960	840	710	630	520	410		
1-1/4"	VR08	3-3/4" x 2-3/4"	50	.020	8*	1	10	1020	880	800	700	620	540	460	410	340	270		
					11	1	13	1080	930	840	750	660	570	490	430	360	280		
					14	1	16	1190	1020	930	820	730	630	540	480	390	310		
					14*	2-5 CL	16	1600	1380	1250	1100	980	850	720	640	530	420		
1"	VR07	5" x 2-3/4"	50	.020	8*	1	10	1210	1040	940	830	740	640	540	480	400	310		
					11	1	13	1270	1090	990	880	770	670	570	510	420	330		
					14	1	16	1320	1140	1030	910	810	700	590	530	440	340		
					14*	2-5 CL	16	1650	1420	1290	1140	1010	870	740	660	540	430		
1-1/4"	VR10	5" x 2-3/4"	50	.020	8*	1	10	1180	1010	920	810	720	630	530	470	390	310		
					11	1	13	1240	1070	970	860	760	660	560	500	410	320		
					14	1	16	1290	1110	1010	890	790	680	580	520	430	340		
					14*	2-5 CL	16	1610	1380	1260	1110	980	850	720	640	530	420		

\*Not recommended for steam applications consult, factory.

Note: Copper tube furnished flared one end standard.

## STEEL ELEMENTS

ALL RATINGS ARE IN BTU/HR/LIN FT AND BASED ON 3 FPS VELOCITY, 65° EAT

TUBE SIZE	CATALOG DESIGNATION	FIN SIZE HEIGHT X WIDTH	FINS PER FT.	FIN THICKNESS IN INCHES	ENCL HEIGHT IN INCHES	TIERS AND CENTERS IN INCHES	MOUNTING HEIGHT IN INCHES	STEAM 215° FACTOR	HOT WATER (AVG.)										
									200°	190°	180°	170°	160°	150°	140°	130°	120°	CORRECTION FACTORS FOR AVERAGE WATER TEMPERATURES	
									1.00	0.86	0.78	0.69	0.61	0.53	0.45	.40	.33	.26	
1"	VR11	3-3/4" x 2-3/4"	40	.024	8*	1	10	830	710	650	570	510	440	370	330	270	220		
					11	1	13	890	770	690	610	540	470	400	360	290	230		
					14	1	16	980	840	760	680	600	520	440	390	320	250		
					14*	2-5 CL	16	1410	1210	1100	970	860	750	630	560	470	370		
1"	VR15	5" x 2-3/4"	50	.024	8*	1	10	890	770	690	610	540	470	400	360	290	230		
					11	1	13	950	820	740	660	580	500	430	380	310	250		
					14	1	16	1040	890	810	720	630	550	470	420	340	270		
					14*	2-5 CL	16	1450	1250	1130	1000	880	770	650	580	480	380		
1-1/4"	VR16	5" x 2-3/4"	50	.024	8*	1	10	910	780	710	630	560	480	410	360	300	240		
					11	1	13	970	830	760	670	590	510	440	390	320	250		
					14	1	16	1060	910	830	730	650	560	480	420	350	280		
					14*	2-5 CL	16	1460	1260	1140	1010	890	770	660	580	480	380		

\*Not recommended for steam application, consult factory.

Notes: 1) Steel fin furnished as .024 thick, painted black.

2) NPT threads furnished on steel elements. Please use domestic fittings for proper installation.

3) The ends can be provided chamfered for field welded fittings when specified.

# Design Data

## COMMERCIAL FINNED TUBE CHARTS FOR RATING CORRECTIONS

For assistance with ratings and selection, please use our online Specifier.

CORRECTION FACTORS FOR WATER TEMPERATURES AND AIR TEMPERATURES OTHER THAN STANDARD															
AVERAGE WATER TEMP. °F	ENTERING AIR TEMPERATURE °F														
	45	55	STD 65	70	75	80	85	90	95	100	110	120	130	140	150
90	.19	.13	.11	.06											
100	.25	.19	.15	.11	.08	.06									
110	.31	.25	.20	.16	.13	.11	.08	.06							
120	.38	.31	.26	.21	.19	.16	.13	.11	.08	.06					
130	.45	.38	.33	.28	.25	.21	.19	.16	.13	.11	.06				
140	.53	.45	.40	.34	.31	.28	.25	.21	.19	.16	.11	.06			
150	.61	.53	.45	.41	.38	.34	.31	.28	.25	.21	.16	.11	.06		
160	.69	.61	.53	.49	.45	.41	.38	.34	.31	.28	.21	.16	.11	.06	
170	.77	.69	.61	.57	.53	.49	.45	.41	.38	.34	.28	.21	.16	.11	.06
180	.86	.77	.69	.65	.61	.57	.53	.49	.45	.41	.34	.28	.21	.16	.11
190	.95	.86	.78	.73	.69	.65	.61	.57	.53	.49	.41	.34	.28	.21	.16
200	1.05	.95	.86	.82	.77	.73	.69	.65	.61	.57	.49	.41	.34	.28	.21
210	1.14	1.05	.95	.91	.86	.82	.77	.73	.69	.65	.57	.49	.41	.34	.28
▶ 215 (STD.)	1.19	1.09	1.00	.95	.91	.86	.82	.77	.73	.69	.61	.53	.45	.38	.31
220	1.24	1.14	1.05	1.00	.95	.91	.86	.82	.77	.73	.65	.57	.49	.41	.34
230	1.34	1.24	1.14	1.09	1.05	1.00	.95	.91	.86	.82	.73	.65	.57	.49	.41
240	1.44	1.34	1.25	1.19	1.14	1.09	1.05	1.00	.95	.91	.82	.73	.65	.57	.49
250	1.55	1.44	1.34	1.29	1.24	1.19	1.14	1.09	1.05	1.00	.91	.82	.73	.65	.57
260	1.66	1.55	1.44	1.39	1.34	1.29	1.24	1.19	1.14	1.09	1.00	.91	.82	.73	.65
270	1.76	1.66	1.55	1.50	1.44	1.39	1.34	1.29	1.24	1.19	1.09	1.00	.91	.82	.73
280	1.87	1.76	1.66	1.60	1.55	1.50	1.44	1.39	1.34	1.29	1.19	1.09	1.00	.91	.82
290	1.99	1.87	1.76	1.71	1.66	1.60	1.55	1.50	1.44	1.39	1.29	1.19	1.09	1.00	.91
300	2.10	1.99	1.87	1.82	1.76	1.71	1.66	1.60	1.55	1.50	1.39	1.29	1.19	1.09	1.00

CORRECTION FACTORS FOR STEAM PRESSURES AND AIR TEMPERATURES OTHER THAN STANDARD																
STEAM		ENTERING AIR TEMPERATURE °F														
PRESSURE		TEMP. °F	45	55	STD 65	70	75	80	85	90	100	110	120	130	140	150
GAUGE	ABS. PSI															
(VAC) 15" HG	7.32	178.9	0.90	0.80	0.70	0.65	0.60	0.56	0.51	0.45	0.39	0.32	0.25	0.18	0.13	0.08
(VAC) 10"	9.78	192.2	1.02	0.91	0.81	0.76	0.71	0.66	0.62	0.55	0.48	0.40	0.33	0.26	0.20	0.14
(VAC) 5"	12.25	202.9	1.11	1.00	0.90	0.85	0.79	0.75	0.70	0.63	0.56	0.48	0.40	0.33	0.27	0.20
▶ 0 PSI	14.696	212.0	1.19	1.09	0.97	0.92	0.87	0.82	0.77	0.70	0.63	0.54	0.46	0.38	0.31	0.25
.899	15.595	215.0	1.22	1.11	1.00	0.95	0.90	0.84	0.80	0.75	0.65	0.57	0.48	0.40	0.33	0.26
5	19.70	227.1	1.34	1.22	1.11	1.05	1.00	0.95	0.90	0.81	0.75	0.66	0.57	0.49	0.41	0.34
10	24.70	239.4	1.45	1.33	1.22	1.17	1.11	1.05	1.00	0.91	0.85	0.75	0.66	0.58	0.50	0.42
15	29.70	249.8	1.55	1.43	1.31	1.26	1.20	1.14	1.09	1.00	0.94	0.84	0.75	0.66	0.57	0.49
20	34.70	258.5	1.63	1.52	1.40	1.33	1.28	1.23	1.17	1.07	1.02	0.92	0.82	0.73	0.64	0.55
25	39.70	266.8	1.71	1.59	1.47	1.41	1.36	1.30	1.25	1.15	1.09	0.98	0.89	0.80	0.71	0.62
30	44.70	274.0	1.78	1.66	1.54	1.48	1.42	1.37	1.31	1.21	1.15	1.05	0.95	0.85	0.76	0.68
40	54.70	286.7	1.91	1.79	1.66	1.61	1.54	1.49	1.43	1.32	1.27	1.16	1.06	0.97	0.87	0.78
50	64.70	297.7	2.02	1.90	1.77	1.71	1.65	1.60	1.54	1.42	1.37	1.26	1.16	1.06	0.96	0.87
60	74.70	307.3	2.10	2.00	1.87	1.81	1.75	1.69	1.63	1.51	1.47	1.35	1.25	1.15	1.05	0.95
70	84.70	316.0	2.20	2.09	1.95	1.89	1.83	1.77	1.71	1.59	1.55	1.44	1.33	1.23	1.12	1.03
80	94.70	323.9	2.27	2.17	2.03	1.97	1.91	1.85	1.80	1.69	1.63	1.52	1.41	1.31	1.20	1.10
90	104.70	331.2	2.36	2.24	2.11	2.05	1.98	1.93	1.87	1.74	1.70	1.59	1.48	1.38	1.28	1.17
100	114.70	337.9	2.43	2.31	2.18	2.11	2.05	2.00	1.94	1.81	1.77	1.65	1.54	1.44	1.33	1.23
125	139.70	352.9	2.59	2.47	2.33	2.27	2.21	2.16	2.10	1.96	1.92	1.80	1.69	1.59	1.48	1.38
150	164.70	365.9	2.73	2.62	2.47	2.43	2.35	2.29	2.23	2.08	2.05	1.94	1.82	1.72	1.61	1.51
175	189.70	377.4	2.86	2.74	2.60	2.54	2.47	2.41	2.35	2.21	2.17	2.05	1.95	1.85	1.73	1.63
200	214.70	387.8	2.95	2.85	2.71	2.63	2.58	2.52	2.47	2.31	2.29	2.17	2.06	1.96	1.84	1.75

From Keenan and Keyes — Linear Interpolation. NOTE: Gauge pressure should be corrected for altitude.

Rate of pitch for steam ½" drop over 20-foot run.

# Design Data

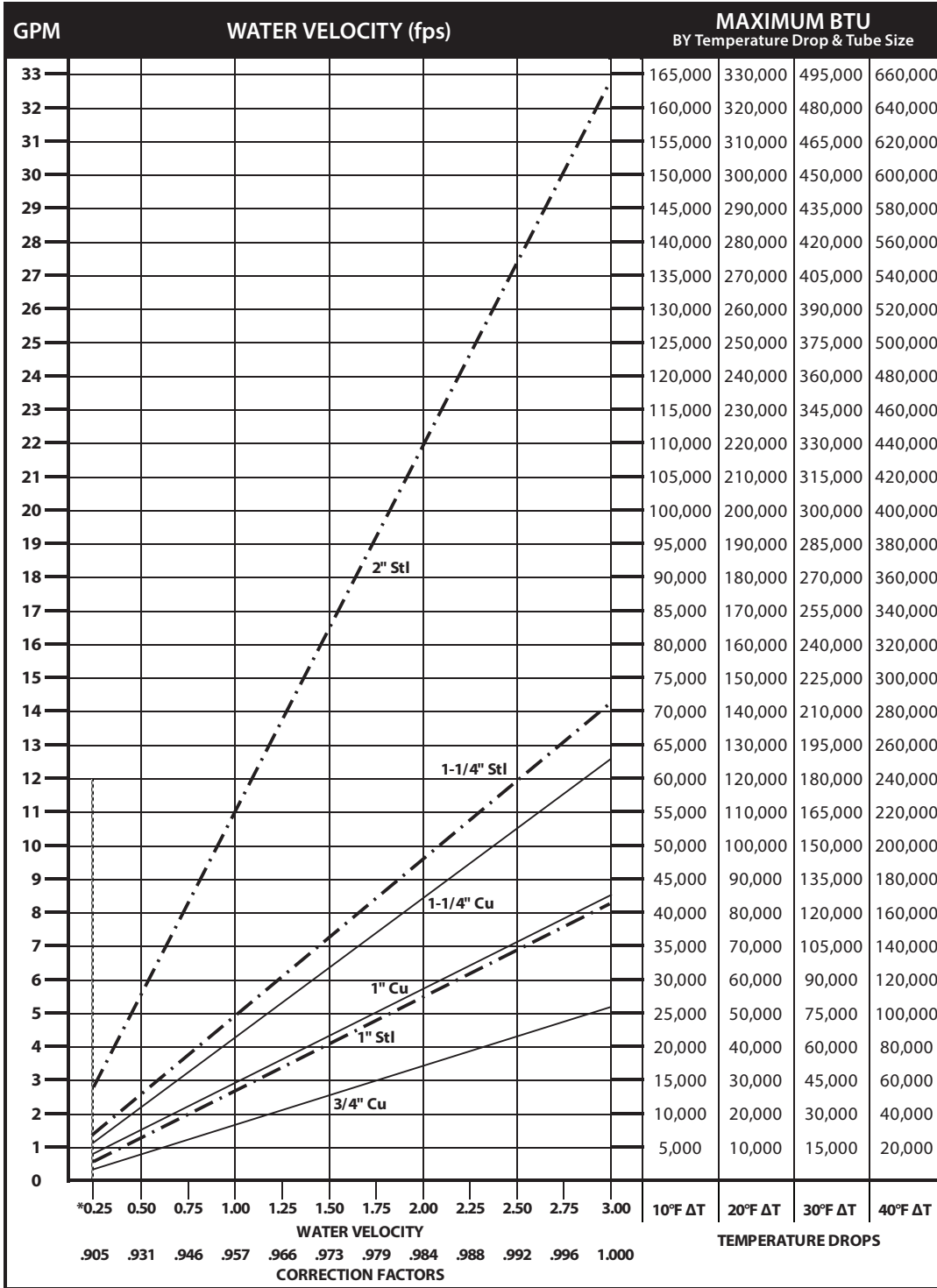

## DYNAMIC FORMULAS

$$\text{BTU} = \text{GPM} \times 500 \times \text{TD}$$

$$\text{GPM} = \left( \frac{\text{BTU}}{500} \right) \div \text{TD}$$

$$\text{TD} = \left( \frac{\text{BTU}}{500} \right) \div \text{GPM}$$

\*Do not design below .25 fps.

## Pressure Drop at Given Water Velocities (Feet of Water per 100 ft. of pipe) based on Hazen - Williams calculation

Nominal Pipe Size	Water Velocity (ft/sec)											
	0.25	0.50	0.75	1.00	1.25	1.50	1.75	2.00	2.25	2.50	2.75	3.00
3/4" Copper	0.06	0.20	0.42	0.72	1.09	1.53	2.04	2.61	3.25	3.95	4.71	5.53
1" Copper	0.04	0.15	0.32	0.54	0.81	1.14	1.52	1.94	2.42	2.94	3.50	4.11
1 1/4" Copper	0.03	0.12	0.25	0.43	0.64	0.90	1.20	1.54	1.92	2.33	2.78	3.26
1" Steel	0.04	0.15	0.32	0.54	0.81	1.14	1.52	1.95	2.42	2.94	3.51	4.12
1 1/4" Steel	0.03	0.11	0.23	0.40	0.60	0.84	1.12	1.44	1.79	2.17	2.59	3.05
2" Steel	0.02	0.07	0.14	0.25	0.37	0.52	0.69	0.89	1.10	1.34	1.60	1.88

# Design Data

## GUARANTEED WORKING PRESSURES

- 1" IPS — 780 at Temperatures up to 650°F.
- 1-1/4" IPS — 660 at Temperatures up to 650°F.
- 2" IPS — 405 at Temperatures up to 650°F.
- 1-1/4" CU — 194 at Temperatures up to 300°F.
- 1" CU 204 at Temperatures up to 300°F.
- 3/4" CU 218 PSI at Temperatures up to 300°F.

MAXIMUM PRESSURES AT OTHER TEMPERATURES ARE AVAILABLE UPON REQUEST.

### Pipe Water Capacities and Quantities Circulated at Velocity of 3 Feet Per Second

Nominal Pipe Size	Pipe I.D. (inches)	Gals Per Lin. Ft.	GPM @ 3' per sec Velocity
3/4" Copper	0.835	0.028	5.12
1" Copper	1.077	0.047	8.52
1 1/4" Copper	1.315	0.071	12.70
1" Steel	1.075	0.047	8.49
1 1/4" Steel	1.395	0.079	14.29
2" Steel	2.115	0.183	32.85

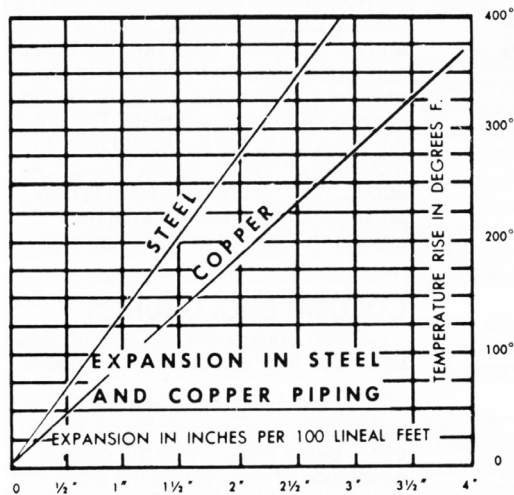

### Glycol Correction Factors

#### Fluid Temperature 200°F

% Solution	Ethylene Glycol	Propylene Glycol
20	.952	.988
30	.921	.968
40	.888	.943
50	.852	.912

#### Fluid Temperature 180°F

% Solution	Ethylene Glycol	Propylene Glycol
20	.946	.982
30	.913	.961
40	.879	.934
50	.842	.902

#### Fluid Temperature 140°F

% Solution	Ethylene Glycol	Propylene Glycol
20	.934	.97
30	.898	.946
40	.861	.916
50	.821	.881

### INLET VS. OUTPUT/BTUH CAPACITY REDUCTION

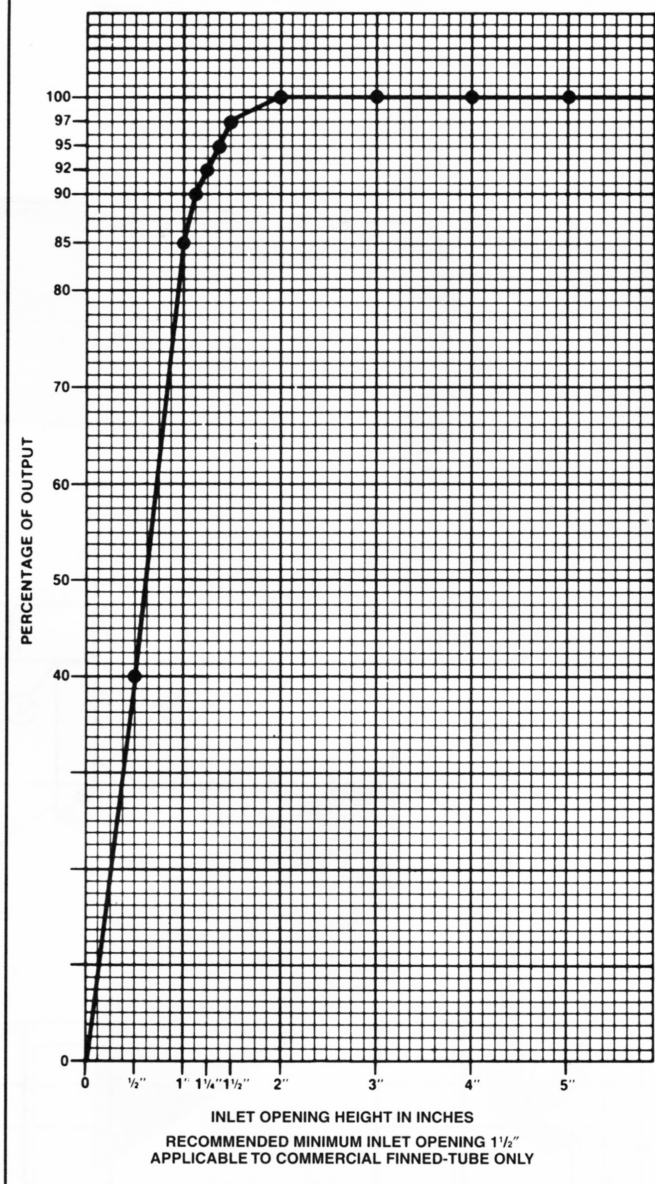

### ALTITUDE FACTORS

Approximate factors for convective heat value at varying altitudes

Altitude	Ferrous Units	Copper Alum. Units
Sea Level	1.000	1.000
1,000 ft.	.984	.969
2,000 ft.	.968	.938
3,000 ft.	.952	.908
4,000 ft.	.936	.878
5,000 ft.	.920	.850
6,000 ft.	.904	.822
7,000 ft.	.889	.795
8,000 ft.	.874	.768
9,000 ft.	.859	.743
10,000 ft.	.844	.718
15,000 ft.	.771	.603
20,000 ft.	.703	.502